

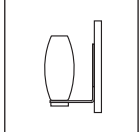
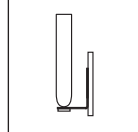
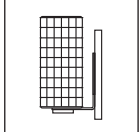
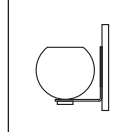
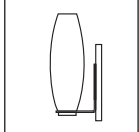
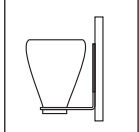
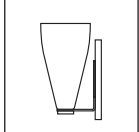
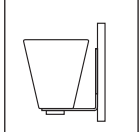

DIAMOND/ SQUARE SCONCES

	<b>CIRO MINI DIAMOND SCONCE</b> 101 830bz 101 831bz 101 832bz 101 833bz		<b>CHIANTI DIAMOND SCONCE</b> 101 820bz 101 821bz 101 822bz 101 823bz
	<b>SIERRA DIAMOND SCONCE</b> 101 114bz		<b>BOBO DIAMOND SCONCE</b> 101 915bz 101 917bz
	<b>CIRO DIAMOND SCONCE</b> 101 116bz 101 118bz 101 119bz 101 121bz 101 122bz 101 123bz 101 124bz 101 125bz		
	<b>LUCY DIAMOND SCONCE</b> 101 126bz 101 127bz 101 128bz		
	<b>ZARA DIAMOND SCONCE</b> 101 151bz 101 152bz 101 153bz 101 154bz 101 156bz 101 157bz		
	<b>BLING DIAMOND SCONCE</b> 101 168bz 101 173bz 101 178bz 101 840bz 101 841bz 101 842bz		
	<b>BLING DIAMOND SCONCE II</b> 101 169bz 101 174bz 101 179bz		
	<b>BOLERO DIAMOND SCONCE</b> 101 336bz 101 337bz 101 338bz 101 339bz		
	<b>RAINBOW DIAMOND SCONCE</b> 101 721bz 101 722bz 101 723bz 101 724bz 101 913bz 101 918bz		
	<b>RAINBOW DIAMOND SCONCE II</b> 101 725bz 101 726bz 101 728bz 101 729bz 101 816bz 101 817bz 101 916bz 101 919bz		

	<b>LAMP TYPE:</b> Bi-Pin <b>MAX WATTAGE:</b> 50W <b>SOCKET TYPE:</b> GY6.35 <b>VOLTAGE:</b> 12V
<b>CIRO MINI DIAMOND SCONCE</b> 101 830bz 101 831bz 101 832bz 101 833bz	<b>CHIANTI DIAMOND SCONCE</b> 101 820bz 101 821bz 101 822bz 101 823bz
<b>SIERRA DIAMOND SCONCE</b> 101 114bz	
<b>CIRO DIAMOND SCONCE</b> 101 116bz 101 118bz 101 119bz 101 121bz 101 122bz 101 123bz 101 124bz 101 125bz	
<b>LUCY DIAMOND SCONCE</b> 101 126bz 101 127bz 101 128bz	
<b>ZARA DIAMOND SCONCE</b> 101 151bz 101 152bz 101 153bz 101 154bz 101 156bz 101 157bz	
<b>BOBO DIAMOND SCONCE</b> 101 915bz 101 917bz	
<b>BLING DIAMOND SCONCE</b> 101 168bz 101 173bz 101 178bz 101 840bz 101 841bz 101 842bz	
<b>BLING DIAMOND SCONCE II</b> 101 169bz 101 174bz 101 179bz	
<b>BOLERO DIAMOND SCONCE</b> 101 336bz 101 337bz 101 338bz 101 339bz	
<b>RAINBOW DIAMOND SCONCE</b> 101 721bz 101 722bz 101 723bz 101 724bz 101 913bz 101 918bz	
<b>RAINBOW DIAMOND SCONCE II</b> 101 725bz 101 726bz 101 728bz 101 729bz 101 816bz 101 817bz 101 916bz 101 919bz	

DIAMOND/ SQUARE SCONCES

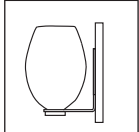
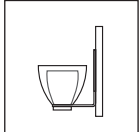
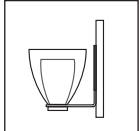
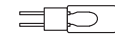
**TECHNICAL SPECIFICATIONS**

Description: 4" Canopy with J-Box and Glass  
Design: Bruck-Team  
Lamp: Bi-Pin GY6.35

**CONTENTS OF DELIVERY**  
fixture complete without lamp

**IMPORTANT SAFETY INSTRUCTIONS**

1. Read all instructions!
2. Turn off power prior to any work on the canopy.
3. THIS PRODUCT MUST BE INSTALLED BY A PERSON FAMILIAR WITH THE CONSTRUCTION AND OPERATION OF THE PRODUCT AND THE HAZARDS INVOLVED, IN ACCORDANCE WITH THE APPLICABLE INSTALLATION CODE.
4. This wall sconce MUST BE HARD WIRED, 120v. For all the wire connections, use Listed Wire Nuts.
5. Only BRUCK Uni-Light fixtures may be used with the wall sconce.
6. Total wattage of the fixture must never exceed the wattage supplied by the low voltage electronic transformer. Please check that the total lamp wattage does not exceed 50W.
7. Secondary connections must be clean and tight to avoid arcing and overheating!
8. Warranty is void in case of unauthorized modifications and/ or improper use.

**READ ALL OF THESE INSTRUCTIONS BEFORE INSTALLATION**

**INSTALLATION INSTRUCTIONS**

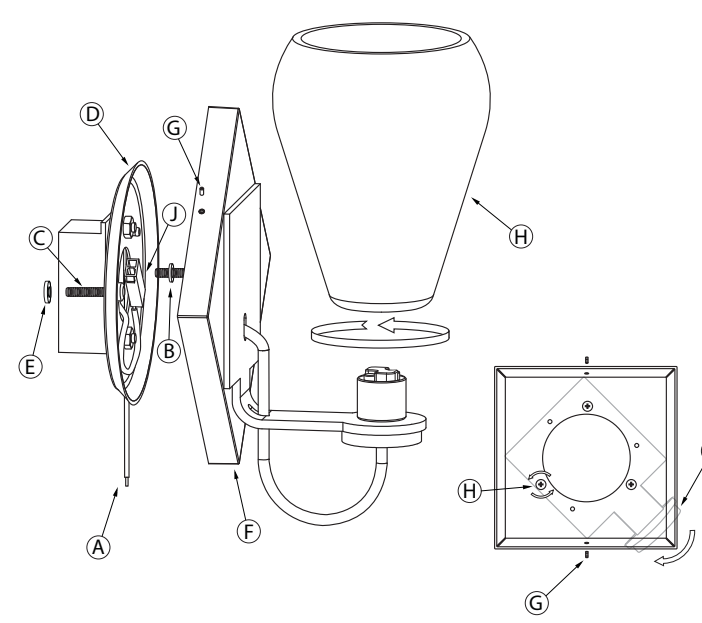

**INSTRUCTIONS FOR USE**

- Begin by connecting the two wires from the transformer (A) to the power cables in the wall. Then slide the notched plastic washer (B) through the mounting screw (C).
- Insert the screw (C) into the mounting plate (D) and slide the plastic washer (E) onto the end of the screw. Align the screws (C) with the J-box and tighten until firmly connected.
- Connect quick connect (J) then place the canopy cover (F) over the mounting plate (D) and secure it with the allen screw (G) located on the side of the base.

**Changing Diamond Canopy to Square**

- To rotate stem, unscrew (G) from the canopy cover (F). Unscrew all 3 screws (H) from the back of canopy, rotate stem (I) and align with holes.
- Remove the glass shade (H) from the fixture by turning the glass counter-clockwise. Insert a Bi-Pin lamp into the socket head to complete the installation.

**NOTE:** Zara glass should not be removed.